

**Footprint RFI filters for**  
**Lenze**  
**8200 vector inverters**



# RF-LZ



- The LZ range, especially for Lenze 8200 vector inverters.
- Help to ensure EMC compliance of machinery and installations using 8200 vector inverters on 250V supplies.
- Footprint filters mount between the inverter and the panel, saving valuable space inside wiring cabinets.
- All filters are designed and manufactured to UL requirements and are CE marked.

### Typical Circuit Schematics

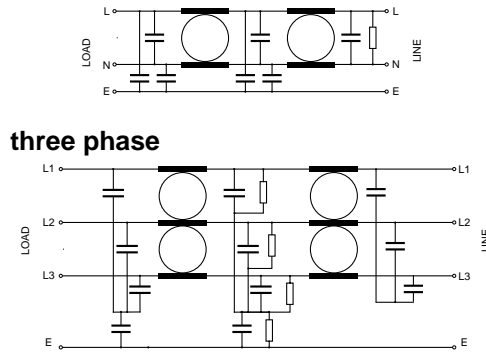

### Footprint Type Dimensions

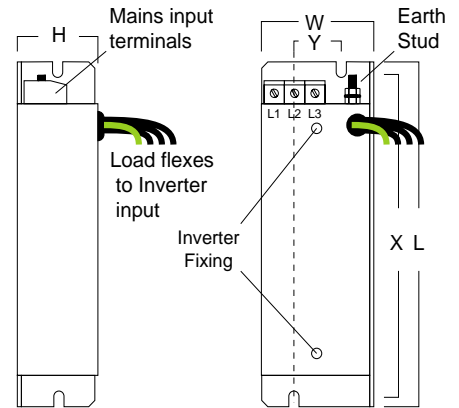

### 200-250V Single Phase

Applied E82EV Inverter	Filter Part No	Rated Current	Max Rated Voltage	Leakage current	External L x W x H (mm)	Mount Dims X x Y x M (mm)	Inverter Fixing	EMC Tested	UL
251K2C 371K2C	RF 1005-LZ	5A	1ph, 250V	3.5mA	217 x 60 x 30	197 x 25 x M6	2 x M6	●	●
551K2C 751K2C	RF 1009-LZ	9A	1ph, 250V	3.5mA	267 x 60 x 40	247 x 25 x M6	2 x M6	●	●
152K2C 222K2C	RF 1020-LZ	20A	1ph, 250V	3.5mA	337 x 60 x 40	317 x 25 x M6	2 x M6	●	●

### 200-250V Three Phase

Applied E82EV Inverter	Filter Part No	Rated Current	Max Rated Voltage	Leakage current Nom / Max	External L x W x H (mm)	Mount Dims X x Y x M (mm)	Inverter Fixing	EMC Tested	UL
551K2C 751K2C	RF 3006-LZ	6A	3ph, 250V		267 x 60 x 40	247 x 25 x M6	2 x M6	●	●
152K2C 222K2C	RF 3013-LZ	13A	3ph, 250V		337 x 60 x 40	317 x 25 x M6	2 x M6	●	●
302K2C 402K2C	RF 3022-LZ	22A	3ph, 250V		337 x 100 x 60	317 x 12.5 x M6	2 x M6	●	●
552K2C 752K2C	RF 3030-LZ	30A	3ph, 250V		337 x 125 x 60	317 x 25 x M6	2 x M6	●	●

EMC testing, UL Approval Status - ✓ Complete, ● Pending

### Earth Leakage Measurements

In single phase applications, the earth leakage current is present all of the time.

For three phase applications under normal conditions with the three phases balanced, earth leakage currents are extremely small - the max values stated are worst possible values such as would occur momentarily during switch on or failure of one or two phases.

# RF-LZ

- The LZ range, especially for Lenze8200 vector inverters.
- Help to ensure EMC compliance of machinery and installations using 8200 vector inverters on three phase supplies.
- Footprint filters mount between the inverter and the panel, saving valuable space inside wiring cabinets.
- All filters are designed and manufactured to UL requirements and are CE marked.

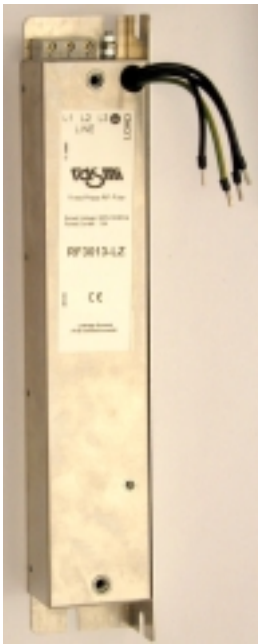

### Typical Circuit Schematics

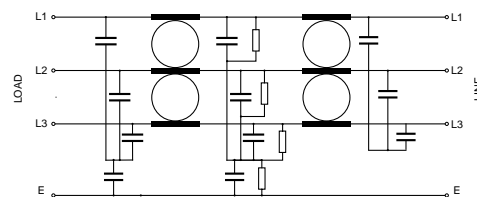

### Footprint Type Dimensions

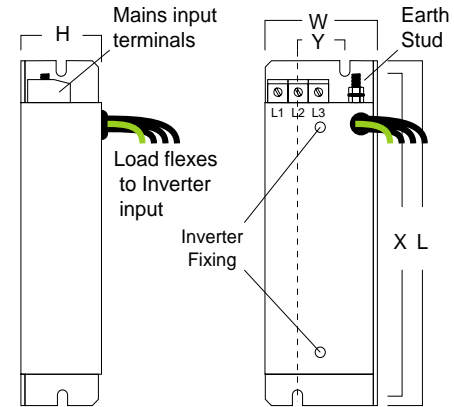

### 350-500V Three Phase

Applied E82EV Inverter	Filter Part No	Rated Current	Max Rated Voltage	Leakage current Nom / Max	External L x W x H (mm)	Mount Dims X x Y x M (mm)	Inverter Fixing	EMC Tested	UL
551K4C 751K4C	RF 3006-LZ	6A	3ph, 500V		267 x 60 x 40	247 x 25 x M6	2 x M6	●	●
152K4C 222K4C	RF 3013-LZ	13A	3ph, 500V		337 x 60 x 40	317 x 25 x M6	2 x M6	●	●
302K4C 402K4C 552K4C	RF 3022-LZ	22A	3ph, 500V		337 x 100 x 60	317 x 12.5 x M6	2 x M6	●	●
752K4C 113K4C	RF 3030-LZ	30A	3ph, 500V		337 x 125 x 60	317 x 25 x M6	2 x M6	●	●
153K4B 223K4B 303K4B	RF 3055-LZ	55A	3ph, 500V		402 x 236 x 90	370 x 205 x M6			
453K4B	RF 3080-LZ	80A	3ph, 500V		580 x 318 x 90	532 x 284 x M10			
553K4B	RF 3100-LZ	100A	3ph, 500V		672 x 318 x 90	624 x 284 x M10			
753K4B 903K4B	RF 3165-LZ	165A	3ph, 500V		750 x 428 x 90	702 x 395 x M10			

EMC testing, UL Approval Status - ✓ Complete, ● Pending

### Design and Test Criteria

Generally with motor drive systems the emission levels are greatly affected by the length of the cable between the drive itself and the motor - longer cables will cause considerably higher emissions.

These inverter / filter combinations have been designed and tested to achieve compliance to :-

EN 55022:1994, Class B for use in domestic / light industrial environments (equivalent to the RF emissions tests of Power Drive Standard EN 61800-3:1996 for drives with <25A input current) when fitted with up to 25m motor output cable and to EN 55011:1991 Group 1, Class A for use in industrial environments (equivalent to the RF emissions tests of Power Drive Standard EN 61800-3:1996 for drives with >25A input current) when fitted with up to 50m motor output cable.

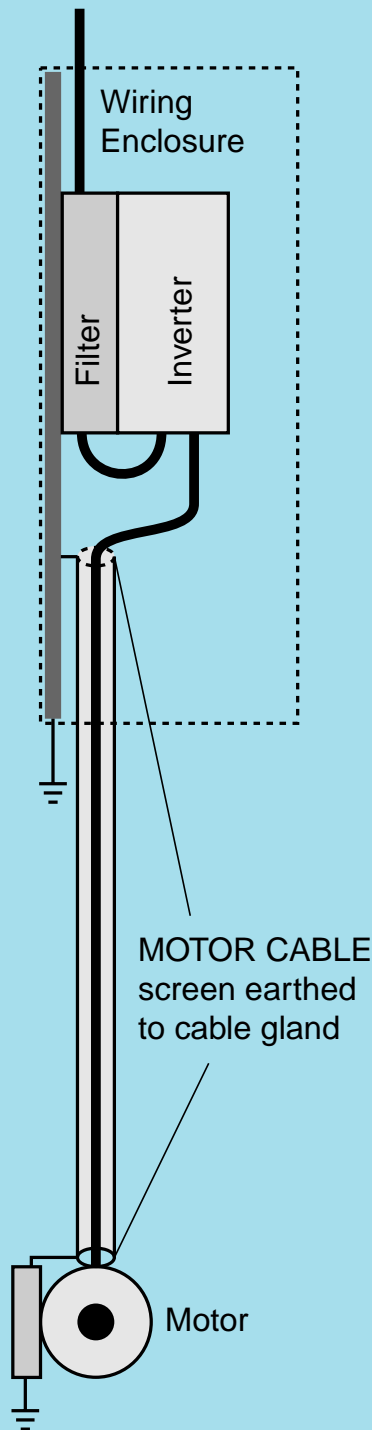

### Filter Installation Notes

To conform to EMC directives, it is essential that good wiring practice is observed and that all installation recommendations are followed.

- ◆ The usual safety procedures when working with electrical equipment must be followed and all electrical connections to the filter, inverter & motor must be made by a qualified electrical technician.
- ◆ Filters should be fitted as closely as possible to the incoming mains supply of the wiring enclosure, usually directly after the enclosures circuit breaker or supply switch.
- ◆ Care should be taken to remove any paint etc. from filter and inverter mounting holes and face area of the panel to ensure the best possible earthing of the units.
- ◆ All lead lengths should be kept as short as possible and incoming mains, outgoing motor cables and control cables should be kept well separated. Cable earth screens should only be stripped back as far as necessary to make connections - screens should be securely earth bonded to the wiring panel.

DUE TO CONTINUAL PRODUCT DEVELOPMENT, SPECIFICATIONS SUBJECT TO CHANGE WITHOUT NOTICE



RASMI ELECTRONICS LTD.

Morrison Road, Annfield Plain, Stanley, Co. Durham DH9 7RX, England.

email: sales@rasmi.com Tel: +44 (0)1207 291300 Fax: +44 (0)1207 291304

Rev: PROVISIONAL ONLY! 0.2